

PART NO.	COLOR (NOTE 2)	HOLE DIA. ±.003 (±0.08)	TOTAL MAT'L THKNS. RANGE	LEG. LENGTH "B" ±.015 (±0.4)	HEAD THICK. "C" ±.015 (±0.4)	HEAD "D" ±.015 (±0.4)	INSTALLATION TOOL	FIG.	
PPR-93-1	NATURAL OR BLACK	.130 (3.3)	.020-.138 (0.5-3.5)	.197 (5.0)	.051 (1.3)	.189 (4.8)	PPR-T1	6	
PPR-93-5		.158 (4.0)	.158-.256 (4.0-6.5)	.315 (8.0)	.059 (1.5)	.295 (7.5)			
PPR-93-22		.161 (4.1)	.024-.177 (0.6-4.5)	.236 (6.0)	.063 (1.6)	.236 (6.0)			
PPR-5	NATURAL	.189 (4.8)	.039-.375 (1.0-9.5)	.421 (10.7)	.059 (1.5)	.280 (7.1)			4
PPR-2		.197 (5.0)	.158-.281 (4.0-7.1)	.382 (9.7)	.280 (7.1)	.429 (10.9)			2
PPR-93-7		NAT. OR BLACK	.197 (5.0)	.059-.197 (1.5-5.0)	.291 (7.4)	.280 (7.1)			6
PPR-93-14B	NATURAL	.217 (5.5)	.118-.276 (3.0-7.0)	.433 (11.0)	.079 (2.0)	.382 (9.7)	PPR-T4	5	
PPR-1		.252 (6.4)	.094-.158 (2.4-4.0)	.449 (11.4)	.185 (4.7)	.437 (11.1)			
PPR-9		.280-.500 (7.1-12.7)	.059-.252 (1.5-6.4)	.366 (9.3)	.079 (2.0)	.469 (11.9)			3

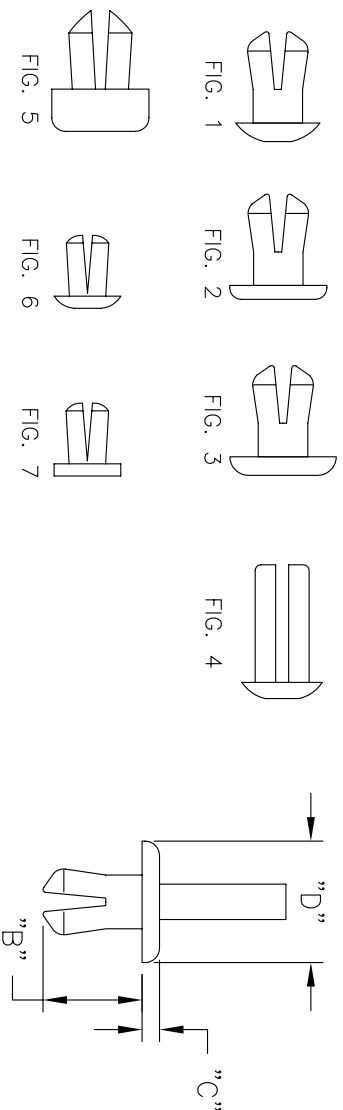

- NOTES:
 1. MATERIAL: NYLON 6/6.
 2. TO ORDER BLACK,
 ADD SUFFIX "B" TO PART NO.

TITLE: PUSH RIVETS		DWG IN IN(MM)		PRINT TYPE	
TOLERANCES UNLESS NOTED .XX=±.020 .XXX=±.015 FRAC=±1/32 ANG=±1°		FILE #	DWN: E.P.	APP:	CA
PPR-CATALOG		MAT'L: SEE NOTES	DT: 11-17-98	DT:	
RE: RICHCO, INC.		RICHCO INC. PO BOX 804238 CHICAGO, 60680 (773) 539-4060		PART #	SEE TABLE
SEE FCN #1150		ENGR DATE		DWG IN IN(MM)	
SEE ENGINEERING FOR DESCRIPTION		ENGR DATE		PRINT TYPE	