

PART NO.	PANEL THKNS. RANGE	HOLE DIAMETER	"A" ±.020	"B" REF.	"C"	"D"	PACKAGE
PGSB-0305	.063-.067 (1.6-1.7)	.189 (4.8)	.26 (6.5)	.13 (3.2)	.24 (6.0)	.050 (1.3)	1000
PGSB-0710	.031-.071 (0.8-1.8)	.394 (10.0)	.48 (12.1)	.28 (7.2)	.26 (6.6)		
PGSB-1013	.031-.118 (0.8-3.0)	.512 (13.0)	.60 (15.3)	.40 (10.2)	.36 (9.1)	.060 (1.5)	500
PGSB-1316	.055-.139 (1.4-3.5)	.630 (16.0)	.71 (18.0)	.50 (12.8)	.41 (10.4)		
PGSB-1519	.039-.118 (1.0-3.0)	.748 (19.0)	.85 (21.7)	.60 (15.3)	.44 (11.1)		
PGSB-1822	.035-.091 (0.9-2.3)	.866 (22.0)	.98 (24.8)	.72 (18.2)	.45 (11.5)		
PGSB-2428	.039-.130 (1.0-3.3)	1.102 (28.0)	1.24 (31.5)	.95 (24.1)	.44 (11.3)		
PGSB-2530	.039-.122 (1.0-3.1)	1.181 (30.0)	1.30 (33.0)	.98 (25.0)	.45 (11.5)		
PGSB-2634	.039-.110 (1.0-2.8)	1.146 (34.2)	1.50 (38.0)	1.03 (26.2)	.45 (11.5)	100	

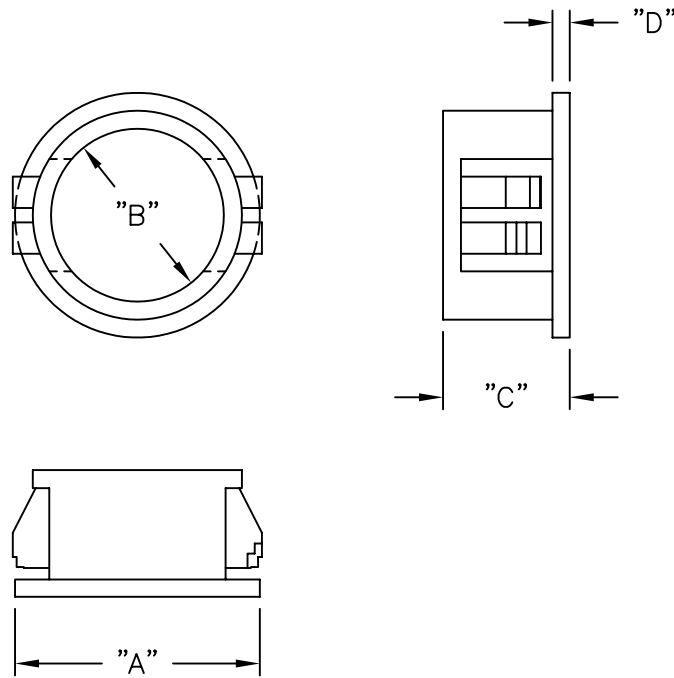

NOTES:

1. MATERIAL: NYLON 66 (RMS-01).
2. COLOR: BLACK.

TITLE: SNAP BUSHINGS CLOSED			DWG IN IN (MM)		FINAL		PRINT TYPE	
C	SEE ECN #637 FOR CHANGES	SM 06.04.03	FILE # PGSB	DWN: P.B.	APP: BR	PART #		CA
B	CHANGED FILE NO. AND TITLE BLOCK	SM 06.20.01	MAT'L: SEE NOTES	DT: 07-18-95	DT: 06/04/03	SEE TABLE		
A	ADDED "D" COLUMN	JK 5.11.00	RE: RICHCO, INC.	RICHCO INC. PO BOX 804238, CHICAGO, 60680 (773) 539-4060				
REV	DESCRIPTION	ENGR DATE	TOLERANCES UNLESS NOTED .XX=±.010 .XXX=±.005 FRAC=1/64 ANG=1°					