

Table of Models

	<p>Description: Peel-A-Way® (KIS) Material: Polyimide Film Index: -269°C to 400°C (-452°F to 752°F)</p>	
	<p>Description: FR-4 (FIS) Material: FR-4 Fiberglass Epoxy Board Index: -40°C to 140°C (-40°F to 284°F)</p>	
	<p>Description: Molded (RIS) Material: High Temp. Liquid Crystal Polymer (LCP) Index: -40°C to 260°C (-40°F to 500°F)</p>	

RIS replaces HCIS, HCS, CIS, and CS.

Features:

- Low insertion force (1 oz. average per pin)
- Screw-machined terminals with multiple finger contacts for reliability
- Closed bottom terminal for 100% anti-wicking of solder
- Tapered entry for ease of insertion
- Custom designs available

Specifications:

Terminals:

Brass - Copper Alloy
(C36000) ASTM-B-16

Contacts:

Beryllium Copper
(C17200) ASTM-B-194

Solder Preform:

Standard: 63Sn/37Pb
Lead-free: 95.5Sn/4.0Ag/0.5Cu

Plating:

G - Gold over Nickel
M - Matte Tin over Nickel
T - Tin/Lead over Nickel

Gold per MIL-G-45204
Matte Tin per ASTM545-97
Tin/Lead per MIL-P-81728
Nickel per QQ-N-290

Options

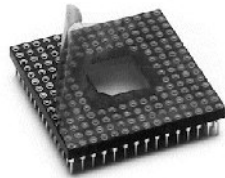

Tape Sealant - add 3M to end of part number

- Removable tape seal protects plated contact in harsh environments
- Sealed socket will not allow dirt and other contaminants to enter socket chamber and become entrapped behind contact fingers
- Spray flux without contaminating contact area

Material

Silicone Backed Polyimide Film, -74°C to 260°C (-100°F to 500°F)
Intermittent to 371°C (700°F)

How To Order

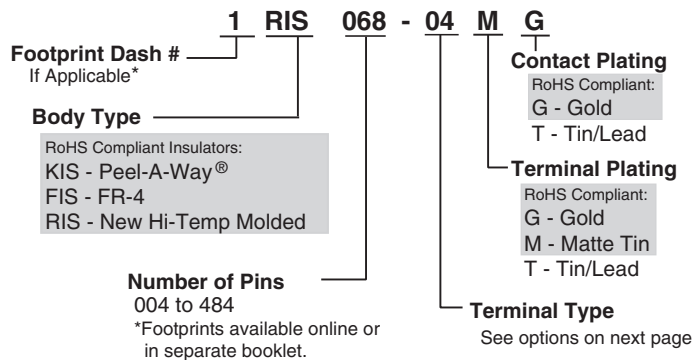

Note: Terminals plated with Matte Tin are available only with Gold plated contacts.
Quick-Turn delivery is not available on products with Matte Tin plating.

Low Insertion Force PGA Sockets .100" (2.54mm) Standard Grid

PGA Sockets

Standard Quick-Turn Terminals

Additional standard and custom terminals available.
See Terminals section online or consult factory.

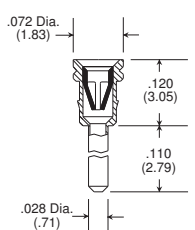
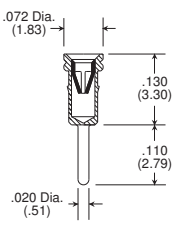
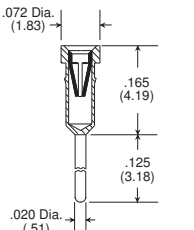
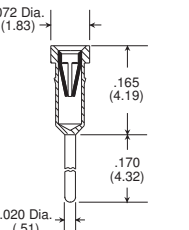
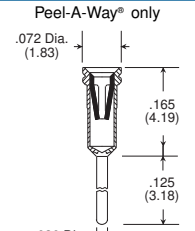
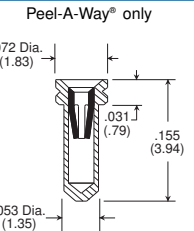
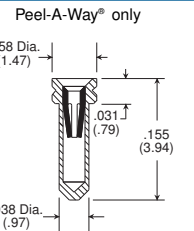
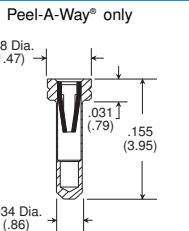
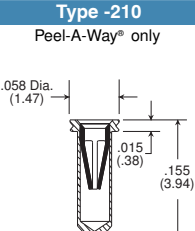
Type -04 .157/(3.99) Hole Depth 	Type -51 	Type -01 Molded or FR-4 only 	Type -29 Molded or FR-4 only 
Type -33 Peel-A-Way® only 	Type -50 Peel-A-Way® only 	Type -85 Peel-A-Way® only 	Type -176 Peel-A-Way® only 
Type -210 Peel-A-Way® only 			

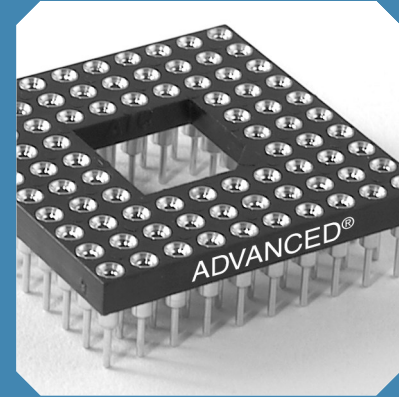

Footprints:

200 Pins
Footprint Number 200-1

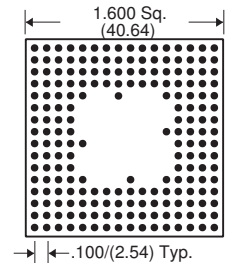

16 x 16 rows

Solder Preform Terminals

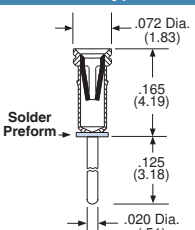
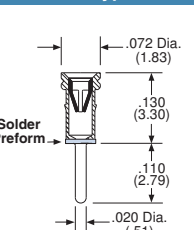
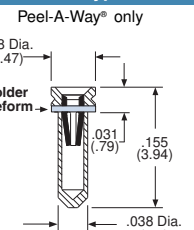
Tin/Lead: Type -150 Lead-free: Type -811 	Tin/Lead: Type -151 Lead-free: Type -812 	Tin/Lead: Type -111 Lead-free: Type -810 Peel-A-Way® only 
--	--	--

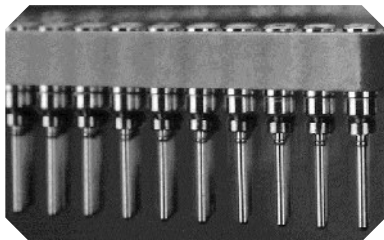

Intrusive Reflow Application

- Combines the labor of socket loading and solder application into one operation.
- Eliminates the use of solder paste and screening operation.
- Eliminates solder bridges and/or solder shorts due to excess solder.
- Ensures a reliable solder joint with controlled solder volume.
- Ideal for surface mount and mixed technology applications.
- For custom solder preform terminal applications consult factory.

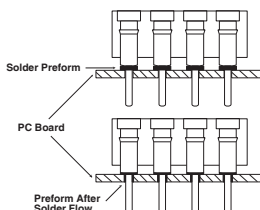

- Full grid insulators loaded to your specific footprint
- Open centers available upon request (consult factory)
- Hundreds of footprints available online
- Use our online Build-A-Part feature or download a Footprints Booklet in PDF format

Available Online:

- Extraction Tools
- RoHS Qualification Test Report



5 Energy Way, West Warwick, RI 02893 USA
Tel: 800.424.9850 | 401.823.5200
Fax: 401.823.8723
info@advanced.com | www.advanced.com
Cat. 16 Rev. 1

inch/(mm)

Products shown covered by patents issued and/or pending. Specifications subject to change without notice.